

# DESIGN NOTES

## LT1182 Floating CCFL with Dual Polarity Contrast – Design Note 99

Anthony Bonte

Current generation portable computers and instruments use backlit liquid-crystal displays (LCDs). Cold-cathode fluorescent lamps (CCFLs) provide the highest available efficiency for backlighting the display. The lamp requires high voltage AC to operate, mandating an efficient, high voltage DC/AC converter. The LCD also requires a bias supply for contrast control. The supply's output must regulate and provide adjustment over a wide range.

Manufacturers offer a wide array of monochrome and color displays. These displays vary in size, lamp drive current, contrast voltage polarity, operating voltage range and power consumption. The small size and battery-powered operation associated with LCD-equipped apparatus dictate low component count and high efficiency. Size constraints place limitations on circuit architecture and long battery life is a priority. All components, including PC board and

hardware, must fit within the LCD enclosure with a height restriction of 5mm to 10mm.

Linear Technology addresses these requirements by introducing the LT<sup>®</sup>1182/LT1183/LT1184F/LT1184. The LT1182/LT1183 are dual fixed frequency, current mode switching regulators that provide the control function for cold-cathode fluorescent lighting and liquid-crystal display contrast. The LT1184F/LT1184 provide only the CCFL function.

The ICs include high current, high efficiency switches, an oscillator, a reference, output drive logic, control blocks and protection circuitry. All of the devices support grounded lamp or floating lamp configurations using a unique lamp current control circuit. The LT1182/LT1183 support nega-

LT, LTC and LT are registered trademarks of Linear Technology Corporation.

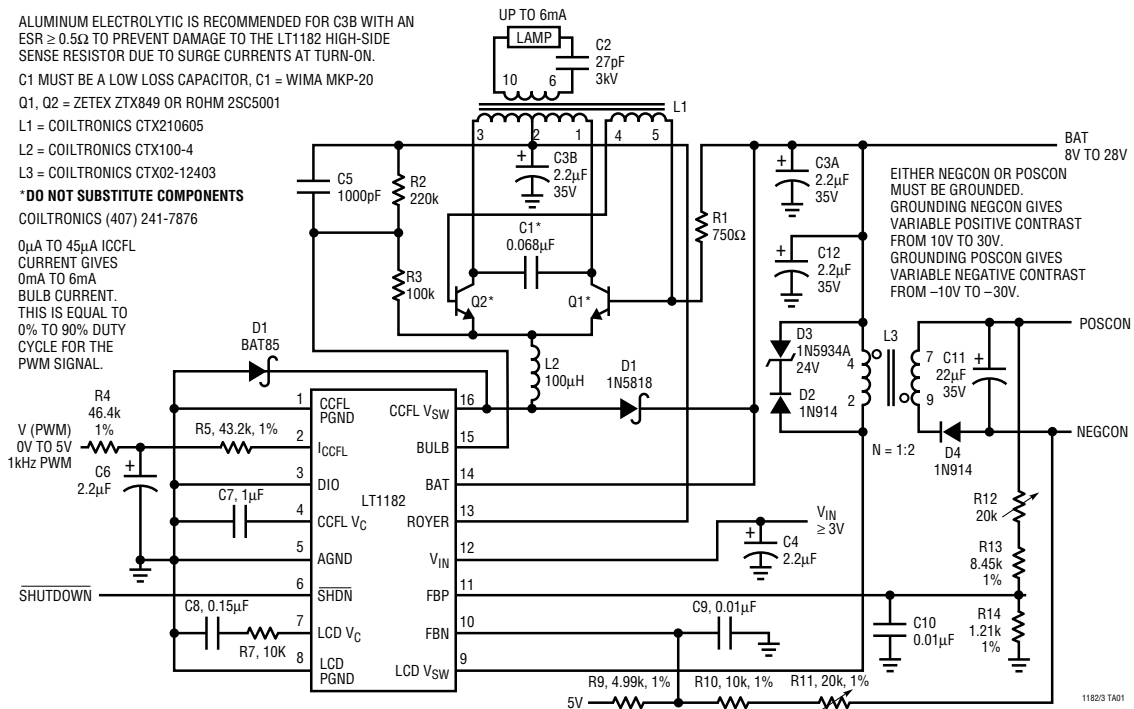
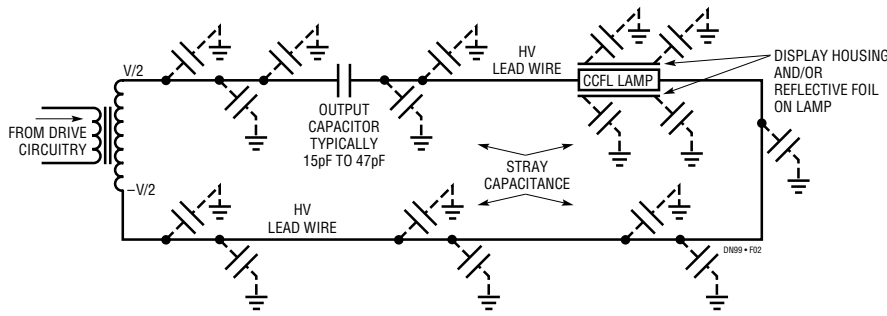

Figure 1. LT1182 Floating CCFL Configuration with Variable Positive/Negative LCD Contrast



**Figure 2. Loss Path Due to Stray Capacitance in a Floating LCD Installation. Differential, Balanced Lamp Drive Reduces This Loss Term and Improves Efficiency**

tive voltage or positive voltage LCD contrast operation with a new dual polarity error amplifier. In short, this new family reduces system power dissipation, requires fewer external components, reduces overall system cost and permits a high level of system integration for a backlight/LCD contrast solution.

Figure 1 is a complete floating CCFL circuit with variable negative/variable positive contrast voltage capability based on the LT1182. Lamp current is programmable from 0mA to 6mA using a 0V to 5V 1kHz PWM signal at 0% to 90% duty cycle. LCD contrast output voltage polarity is determined by which side of the transformer secondary (either POSCON or NEGCON) the output connector grounds. In either case, LCD contrast output voltage is variable from an absolute value of 10V to 30V. The input supply voltage range is 8V to 28V. The CCFL converter is optimized for photometric output per watt of input power. CCFL electrical efficiency up to 90% is possible and requires strict attention to detail. LCD contrast efficiency is 82% at full power.

Achieving high efficiency for a backlight design requires careful attention to the physical layout of the lamp, its leads and the construction of the display housing. Parasitic capacitance from any high voltage point to DC or AC ground creates paths for unwanted current flow. This parasitic current degrades electrical efficiency. The loss term is related to  $1/2CV^2f$  where C is the parasitic capacitance, V is the voltage at any point on the lamp and f is the royer operating frequency. Losses up to 25% have been observed in practice. Figure 2 indicates the loss paths present in a typical LCD enclosure for a floating lamp configuration. Layout techniques that increase parasitic capacitance include long high voltage lamp leads, reflective metal foil around the lamp and displays supplied in metal enclosures.

Lossy displays are the primary reason to use a floating lamp configuration. Providing symmetric, differential drive to the lamp reduces the total parasitic loss term by one-half in comparison to a grounded lamp configuration. As an added

benefit, floating lamp configurations eliminate field imbalance along the length of the lamp. Figure 3 illustrates this effect. Eliminating field imbalance improves the illumination range from about 6:1 for a grounded lamp configuration to 30:1 for a floating lamp configuration. Figure 4 is a graph of normalized Nits/Watt versus lamp current for a typical manufacturer's display with a 6mA lamp. Performance for the display is compared in a floating lamp configuration versus a grounded lamp configuration. The benefit of reduced parasitic loss is readily apparent.

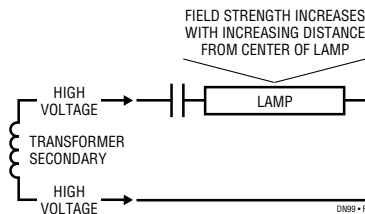

**Figure 3. Field Strength vs Distance for a Floating Lamp. Improving Field Imbalance Permits Extended Illumination Range at Low Levels**

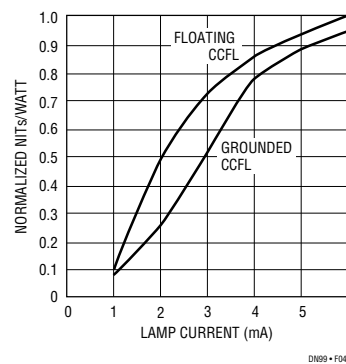

**Figure 4. Normalized Nits/Watts vs Lamp Current**

For literature on our Switching Regulators, call **1-800-4-LINEAR**. For applications help, call (408) 432-1900, Ext. 361